

## Model / Model

## A175-400Nm 0800-1,60

<b>Yük-Yolcu</b> / Load-Person	800 Kg (10 Person)
<b>Hız</b> / Speed	1,6 m/s
<b>Aski</b> / Roping	2 / 1
<b>Kasnak-Hatve</b> / Sheave-Pitch	ø320 x 5 x ø8 / 14
<b>V Kanal Açısı</b> / V Groove Angle	40°
<b>Enkoder</b> / Encoder	Endat / Sincos / Biss-C
<b>Fren</b> / Brake Magnet	200 V DC
<b>Duty Cycle</b> / Görev Faktörü	S3 40%
<b>Machine Weight</b> / Makine Ağırlığı	260Kg
<b>Maks. Statik Yük</b> / Max. Static Load	6000Kg (2/1)
<b>Tork</b> / Torque	400 NM
<b>Bağlantı</b> / Connect	(Δ) Delta
<b>Devir</b> / Motor RPM	190 RPM
<b>Frekans</b> / Frequency	69,67 Hz
<b>Kutup Sayısı</b> / Number of Poles	44 Poles
<b>Motor Gücü</b> / Motor Power	7,96 Kw
<b>Akım</b> / Current	25,5 A
<b>Voltaj</b> / Terminal Voltage	257 V AC
<b>Cosφ</b> / Cos φ	0,89

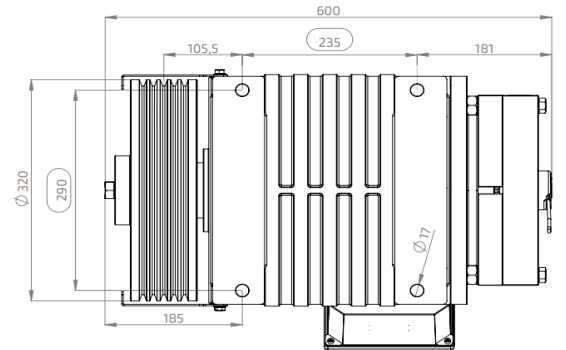
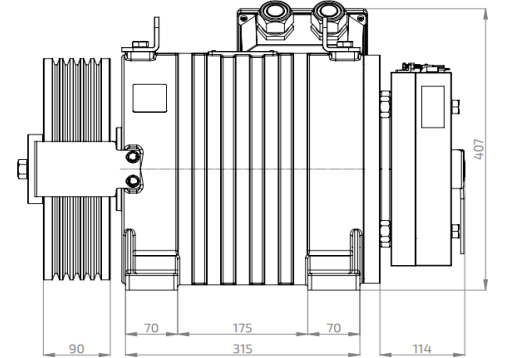
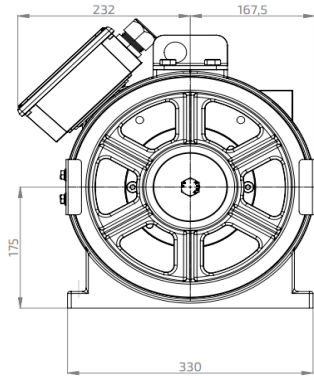

Astes Asansör ölçüler ve veriler üzerinde değişiklik yapma hakkına sahiptir.

The dimensions and data are subject to change without notice.

Factory: Fevzipasa Mah. Gülbağlar Sok. No:9 Değirmenköy - Silivri - İstanbul - TÜRKİYE

T:+90 212 723 53 73 (pbx) F: +90 212 723 53 76

Web: www.astes.com.tr E-Mail: astes@astes.com.tr