

Model / Model	:	A4-180 VVVF 3000-0,40
Kontrol / Control	:	VVVF/ Encoder
Askı / Roping	:	2 / 1
Yük / Load	:	3000 Kg (2/1)
Hız / Speed	:	Max. 0,40 m/s (2/1)
Motor / Motor	:	380 VAC / 50Hz
Motor Gücü / Motor Power	:	15 Kw
Devir / Motor RPM	:	1500 RPM
Akım / Motor Current	:	33 A
Aktarma Oranı / Ratio	:	50 / 1
Kasnak-Hatve / Sheave-Pitch	:	ø560 x 6 x ø12 / 19
Kanal Açısı / Groove Angle	:	40°
Fren / Brake Magnet	:	195 VDC
Yağ-Kapasite / Gear Oil-Capacity	:	Mobil Gear 600 XP320 / 8Lt.
Maks. Statik yük / Max. Static Load	:	10000 Kg (2/1)

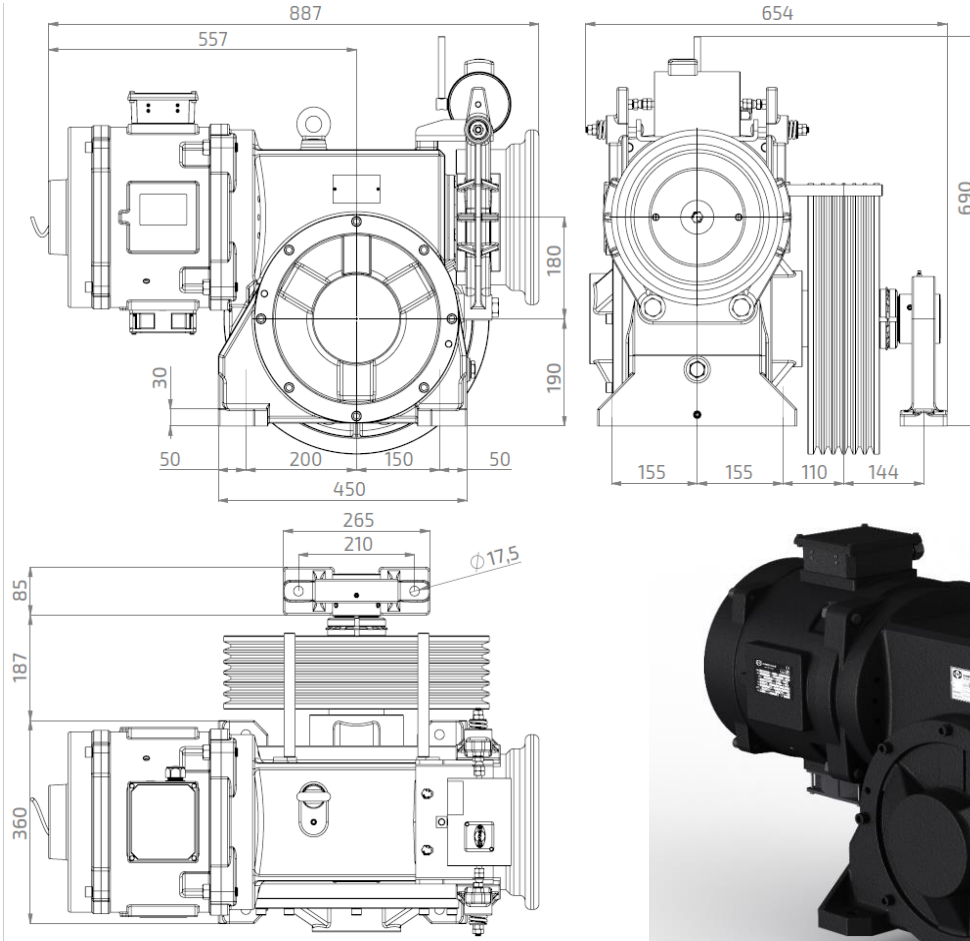

Astes Asansör ölçüler ve veriler üzerinde değişiklik yapma hakkına sahiptir.

The dimensions and data are subject to change without notice.