

<b>Model / Model</b>	:	<b>A4-135 AC2 450-1,0</b>
<b>Kontrol / Control</b>	:	AC2 Two Speed
<b>Askı / Roping</b>	:	1 / 1
<b>Yük / Load</b>	:	450 Kg
<b>Hız / Speed</b>	:	1/0,25 m/s
<b>Motor / Motor</b>	:	380 VAC / 50Hz
<b>Motor Gücü / Motor Power</b>	:	5,5 / 1,37 Kw
<b>Devir / Motor RPM</b>	:	1500 / 375 RPM
<b>Akım / Motor Current</b>	:	12 / 8 A
<b>Aktarma Oranı / Ratio</b>	:	40 / 1
<b>Kasnak-Hatve / Sheave-Pitch</b>	:	ø480 x 4 x ø10 / 16
<b>Kanal Açısı / Groove Angle</b>	:	40°
<b>Fren / Brake Magnet</b>	:	195 VDC
<b>Yağ-Kapasite / Gear Oil-Capacity</b>	:	Mobil Gear 600 XP320 / 3Lt.
<b>Maks. Statik yük / Max. Static Load</b>	:	3500Kg

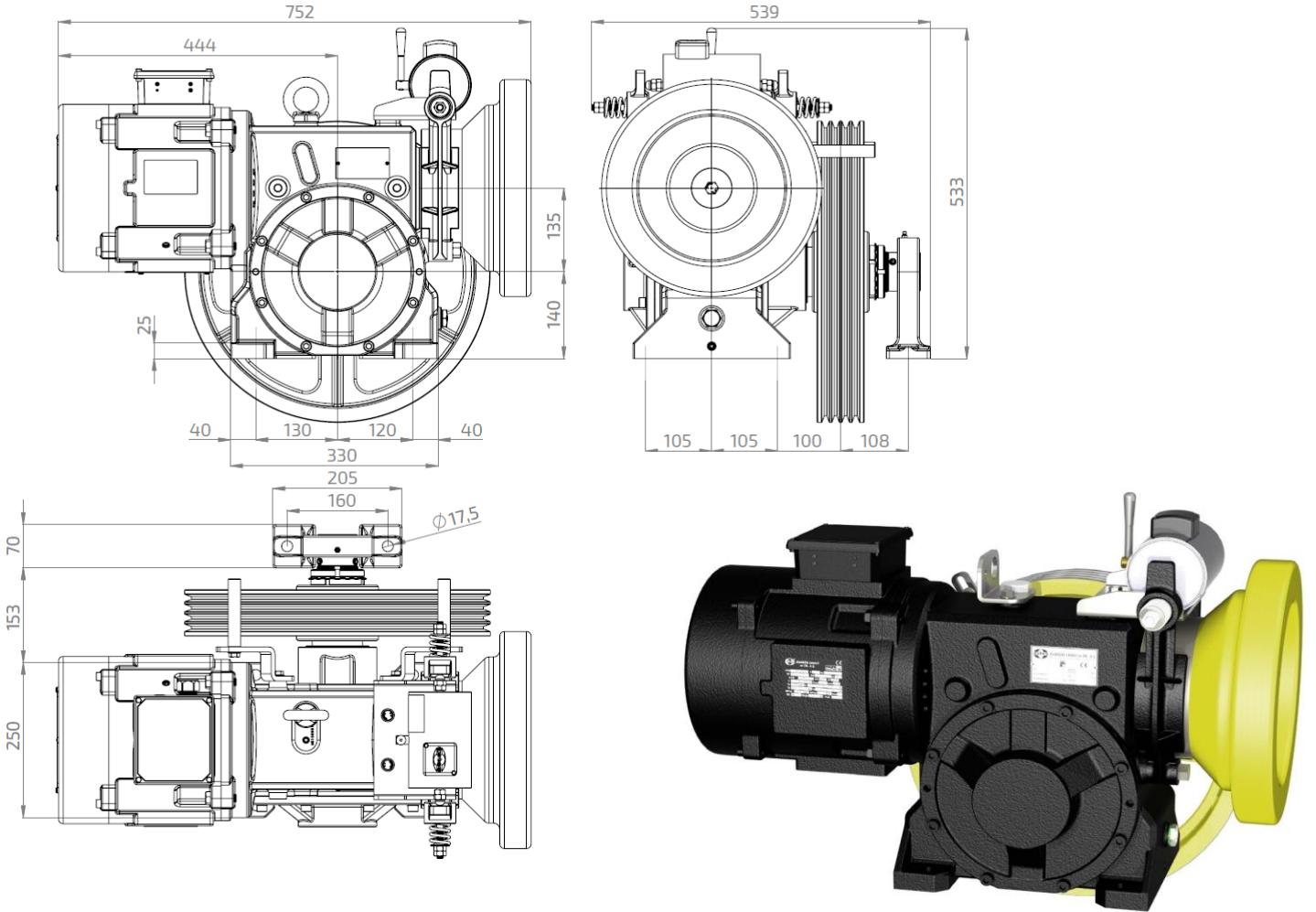

Astes Asansör ölçüler ve veriler üzerinde değişiklik yapma hakkına sahiptir.

The dimensions and data are subject to change without notice.